

Cooling & Heating Division

FLOAT TRAP
With Thermostatic Air Vent
TFT-TV-N - CI/CS

TFT-TV-N

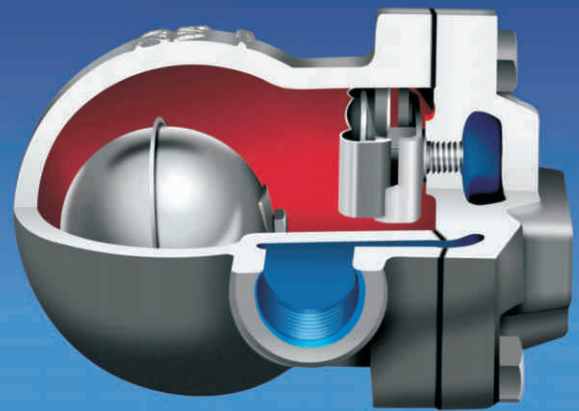

FIT AND FORGET TRAP FOR SATURATED STEAM APPLICATION

MAIN FEATURES

- SG Iron body with SS internals and built in thermostatic Air Vent.
- Designed for varying loads with continuous discharge.
- Unaffected by instantaneous pressure changes.
- Used for removing condensate from steam heating equipments at saturated temperature as soon as it is formed

Installation

Cover part can be arranged according to horizontal or vertical installation .

CONNECTIONS

Screwed	NPT, BSP
Flanged	Available

SIZES

15 - 25 mm	1/2" - 3/4" - 1" inches
------------	-------------------------

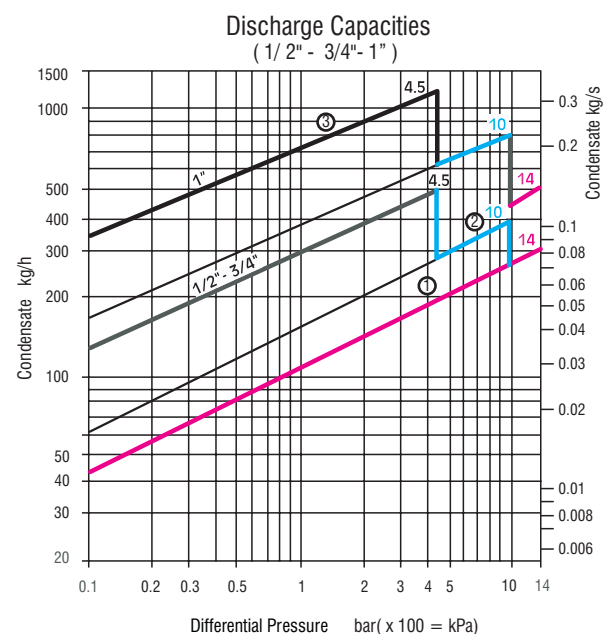

Chart :

- 1- For 14 bar diff. press.
- 2- For 10 bar diff. press.
- 3- For 4.5 bar diff. press.

SPECIFICATIONS

OPERATING CONDITIONS		Cast Iron Body	Cast Steel Body
Max.Allowable Pressure	PMA (bar)	25	40
Max.Allowable Temperature	TMA (°C)	300	400
Max.Operating Pressure	PMO (bar)	16	32
Max.Dif ferential Pressure	PMD (bar)	4.5 - 10 - 14	4.5 - 10 - 14
Max.Operating Temperature	TMO (°C)	250	400

WEIGHTS			
Connections	Flanged	Screwed	Butt weld
Sizes mm	15-20-25	1/2 - 3/4 - 1	—
Weights kgs	4.05 - 4.8 - 7.1	3.2 - 3.2 - 4.7	—

SPARE PARTS		MATERIAL
1	Body	GGG 40.3 or GSC 25
2	Cover	GGG 40.3 or GSC 25
3	Thermostatic Capsule	Stainless Steel
4	Air Vent Seat	Stainless Steel AISI 304
5	Float Seat	Stainless Steel AISI 304
6	Main Valve (ball)	Stainless Steel
7	Float Lever	Stainless Steel AISI 304
8	Float	Stainless Steel AISI 304

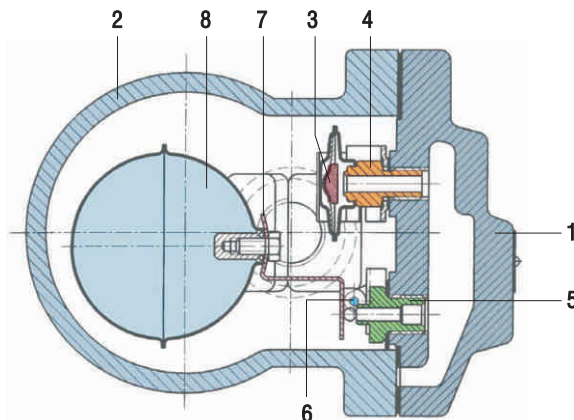

Size	A	K	B	C	D
15	150	150	108	68	122
20	150	150	108	68	122
25	160	167	108	107	145

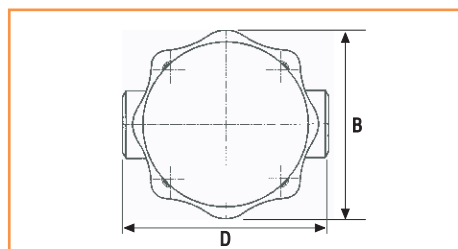
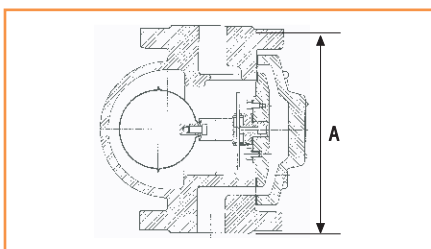
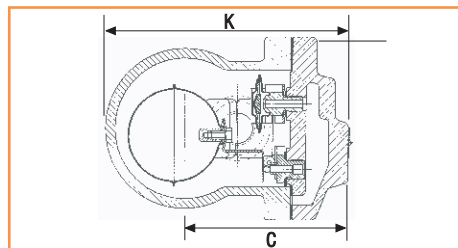
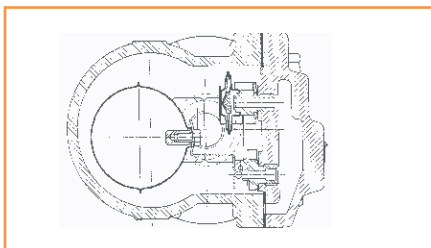

Sustainable Solutions in Energy & Environment

COOLING & HEATING DIVISION

Services SBU - FEMS

D - 13, MIDC Industrial Area, R. D. Aga Road, Chinchwad, Pune 411 019. INDIA
Tel.: +91-20-2747 5941
Fax: +91-20-2747 7080
E-mail: info.c&hservices@thermaxindia.com

AHMEDABAD 380 006

Tel.: (079) 2657 5408 / 5341 / 7073
Fax: (079) 2657 7270
E-mail: mambiar@thermaxindia.com

BANGALORE 560 020

Tel.: (080) 2346 7761 - 64
Fax: (080) 2346 7760
E-mail: adminblr@thermaxindia.com

CHENNAI 600 018

Tel.: (044) 2435 3831 - 34
Fax: (044) 2435 3841
E-mail: chennaidivsupp@thermaxindia.com

HYDERABAD 500 482

Tel.: (040) 2339 6820, 2331 0254
Fax: (040) 2331 2335
E-mail: hyd_sec@thermaxindia.com

MUMBAI 400 016

Tel.: (022) 2204 5391, 2204 5324
Fax: (022) 2204 0859
E-mail: psecretat@thermaxindia.com

NEW DELHI 110 057

Tel.: (011) 2614 5319, 2614 5701
Fax: (011) 2614 5311, 2614 8679
E-mail: psupport@thermaxindia.com

KOLKATA 700 016

Tel.: (033) 2282 6711 - 13
Fax: (033) 2282 6769
E-mail: mbiswas@thermaxindia.com

VADODRA 390 005

Tel.: (0265) 231 4802, 234 5442
Fax: (0265) 231 0051
E-mail: pbaroda@thermaxindia.com

www.thermaxindia.com

International offices at
Indonesia, Russia, Kazakstan, Saudi Arabia, Malaysia, Bangladesh, Sri Lanka, Hong Kong, China Thailand, UAE, Kenya, Nigeria, Brazil, UK, USA

Thermax Business Portfolio

Boilers & Heaters

Absorption Cooling

Air Pollution Control

Captive Power

Chemicals

Water & Waste Solutions

Special inspection and certification available on request

In view of our constant endeavor to improve the quality of our products, we reserve the right to alter or change specifications without prior notice.